

Case

Stainless steel,
Gas tight: leakage rate $\leq 1 \cdot 10^{-5}$ mbar · l / s
Test method: spectrometry of helium mass
Filling: dry nitrogen

Window

Laminated safety glass

Bezel ring

Cam ring (bayonet type), stainless steel
fixed with 1 welded spot

Ingress protection

IP 65 per EN 60529 / IEC 529 / NEMA 4

Weight

Approx. 1.0 kg

Options

- Other process connections and position
- Acrylic glass window
- Silicon oil case filling
- Compensation for gas mixtures

Dimensions in mm

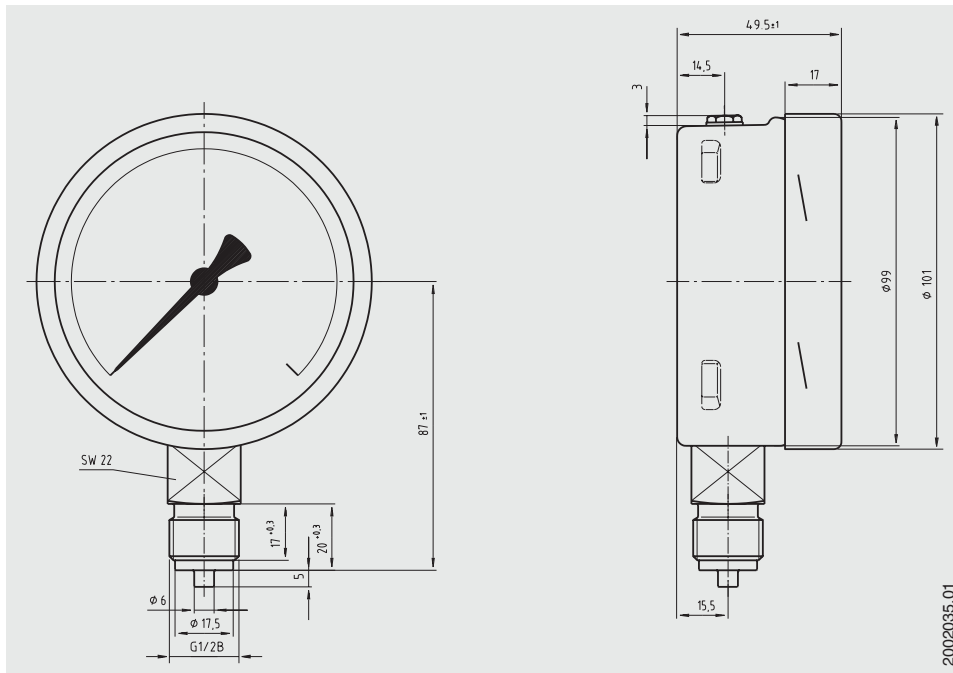

Ordering information

Model / Nominal size / Scale range / Connection size / Connection position / Filling pressure / Calibration pressure / Options

© 2009 WIKA Alexander Wiegand SE & Co. KG, alle Rechte vorbehalten.
Die in diesem Dokument beschriebenen Geräte entsprechen in ihren technischen Daten dem derzeitigen Stand der Technik.
Änderungen und den Austausch von Werkstoffen behalten wir uns vor.



WIKAI
WIKAI Alexander Wiegand SE & Co. KG
Alexander-Wiegand-Straße 30
63911 Klingenberg/Germany
Tel. +49 9372 132-0
Fax +49 9372 132-406
info@wika.de
www.wika.de